

مشروع الطرق المؤدية إلى التعليم العالى

الشركاء

- كلية الهندسة، جامعة القاهرة. - مؤسسة فورد.
- جامعات: القاهرة، وعين شمس، وأسيوط، وحلوان، والمنيا، وجنوب الوادى، والفيوم، وبنى سويف، وسوهاج.
- جمعية جيل المستقبل. - المجلس القومى للمرأة.

الكتب الانجليزية

- 1- Planning and Controlling.
- 2- Systems and Creative Thinking.
- 3- Research Methods and Writing Research Proposals.
- 4- Statistical Data Analysis.
- 5- Teams and Work Groups.
- 6- Risk Assessment and Risk Management.
- 7- Communication Skills.
- 8- Negotiation Skills.
- 9- Analytical Thinking.
- 10- Problem Solving and Decision Making.
- 11- Stress Management.
- 12- Accounting for Management and Decision Making.
- 13- Basics of Managerial Economics.
- 14- Economic Feasibility Studies.
- 15- Health, Safety and Environment.
- 16- Wellness Guidelines: Healthful Life.
- 17- General Lectures Directory.

موقع المشروع على شبكة الإنترنت

www.Pathways.cu.edu.eg

رسالة المشروع

رفع مهارات الطلاب والخريجين من الجامعات المختلفة لمساعدتهم على الاندماج السريع فى المجتمع وصقل مهاراتهم بما يتناسب مع حاجة البحث العلمى وسوق العمل.

مطبوعات البرامج التدريبية

الكتب العربية

- ١- المحاجة: طرق قياسها وأساليب تنميتها.
- ٢- القواعد اللغوية الأساسية للكتابة العلمية.
- ٣- دليل مشروعات التخرج من برنامج "تنمية مهارات البحث العلمى".
- ٤- التخطيط والرقابة.
- ٥- التفكير النمطى والإبداعى.
- ٦- مناهج البحث وكتابة المشروع المقترح للبحث.
- ٧- التحليل الإحصائى للبيانات.
- ٨- تكوين الفرق والعمل الجماعى.
- ٩- تقييم وإدارة المخاطر.
- ١٠- مهارات الاتصال.
- ١١- مهارات التفاوض.
- ١٢- التفكير التحليلى: القدرة والمهارة والاسلوب.
- ١٣- حل المشاكل وصنع القرار.
- ١٤- إدارة الضغوط.
- ١٥- المحاسبة للإدارة وصنع القرار.
- ١٦- أساسيات الاقتصاد الإدارى.
- ١٧- دراسات الجدوى الاقتصادية.
- ١٨- البيئة والتنمية المستدامة: الإطار المعرفى والتقييم المحاسبى.
- ١٩- إرشادات الصحة العامة: من أجل حياة صحية.
- ٢٠- إنشاء المشروعات الصغيرة وتنميتها.
- ٢١- أضواء حول الموضوعات المعاصرة.

الناشر: مركز تطوير الدراسات العليا والبحوث - كلية الهندسة - جامعة القاهرة.

فاكس: ٥٧٠٣٦٢٠ (+٢٠٢)

ت: ٥٧١٦٦٢٠ (+٢٠٢)، ٥٦٧٨٢١٦ (+٢٠٢)

بريد إلكترونى: capscu@capscu.com

الموقع على شبكة الإنترنت: www.capscu.com

إعداد
د. أيمن عامر

—

القاهرة
٢٠٠٧

:

:

-

(+) - - - :
(+) :

www.capsu.com :

www.Pathways.cu.edu.eg :

Pathways@Pathways.edu.eg :

رقم الإيداع بدار الكتب المصرية: /

الترقيم الدولي: ISBN 977-403-133-4

"

"

.

/

/

.

:

.

.

.

.....

.

.

''

''

.

-

-

-

-

.

-

-

.

.

-

-

"

"

.

:

-

.

.

:

-

-

-

-

-

-

"

"

.

(-)

(-)

.

.

—

—

.

.

.

.

.

.

:

:

:

-

:

-

:

-

-

-

:

-

-

-

-

-

-

:

-

-

-

-

:

-

-

-

-

-

-

:

:

:

-

-

-

-

-

-

-

-

			:(-)
		:	:(-)
()		()	:(-)
			:(-)
			:(-)
			:(-)
			:(-)
	()		:(-)
			:(-)
			:(-)
())	:(-)
-			:(-)
			:(-)

:(-)

:(-)

:(-)

:(-)

:(-)

:(-)

:(-)

:(-)

:(-)

:(-)

:

.

•

•

.

•

•

.

.

•

•

.

.

•

)

.(

()

Guilford

(¹) Analytical thinking.

()

)⁽¹⁾

()⁽¹⁾

.(Hayduck, 1990)⁽¹⁾(

)

.(Reber, 1990) (...

" "

:

:

()

:

-
- (1) Convergent thinking.
 - (2) Analytical problem solving
 - (3) Creative problem solving
 - (4) Divergent thinking
-

-
-
-
-
-

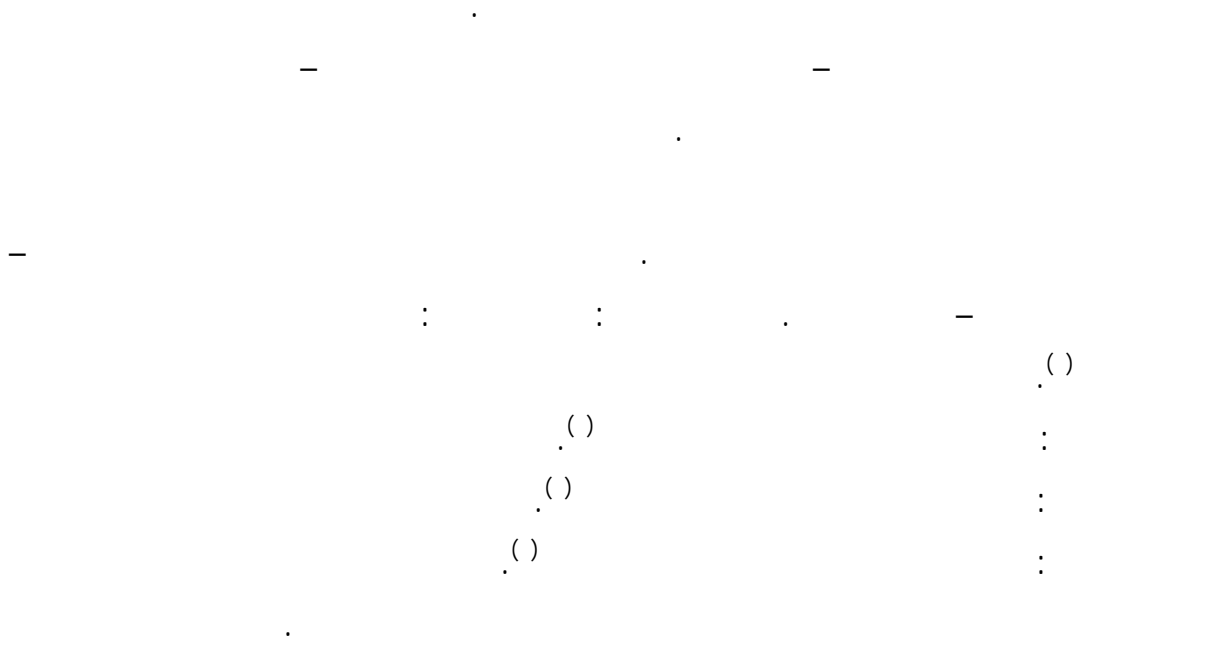

-
- (1)Cognitive ability
 - (2)Cognitive process
 - (3)Cognitive skill
 - (4)Cognitive style
-

(Desimone, 2002)

.()
" "
" " " "
" " " "

(Stand fast logic Ltd, 2001)

(Reber, 1990) (....)

:

. -
. -
. -

-
- (1) Hypothesis Contracture
 - (2) Restructure
 - (3) Synthetical Thinking
 - (4) System thinking
-

. -

. -

.() -

.() -

: -

.

" " " "

.

-

-

()

)

(

)

(OHara & Sternberg, 199)

.

:(-)

(

:

(Bartellet, 2002)

-
- (1) Systemic thinking
 - (2) Critical thinking
-

-

).

.(

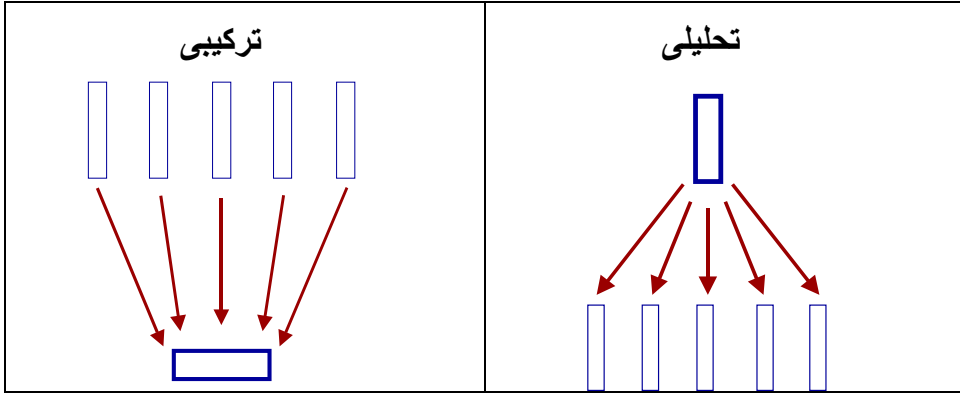

:(-)

-

)

.(

-

)

()

.()

-

)

.(

()

-

Systematic Thinking

.Systemic Thinking

System Thinking

Systematic Thinking

)
(....
:()

System Thinking

)

(
) Systemic
(...)
(....

()

" "

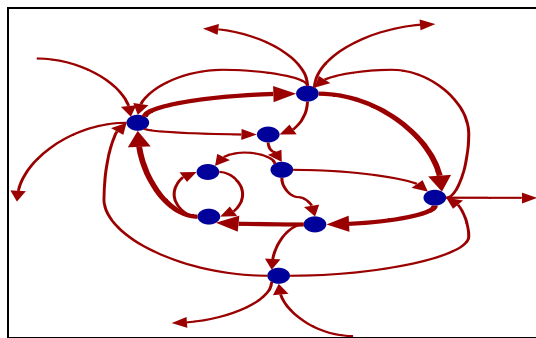

: (-)

- (-)

- "

"

.

.

-

" "

Mayfield

" "

"

Keri

Critical

.() " "

" O Hara

" "Sternberg

"

"

.(Sternberg, & OHara ,1999)

"

.()

.

) (

)

"

(

()
()
) :
) ()
) ()
()
()
()

-

" (see: Guilford, 1989)

()

" "

:

(-)

" "

Parnes

(Isaksen, Dorval, Trefernger., 1994)

Isaksen

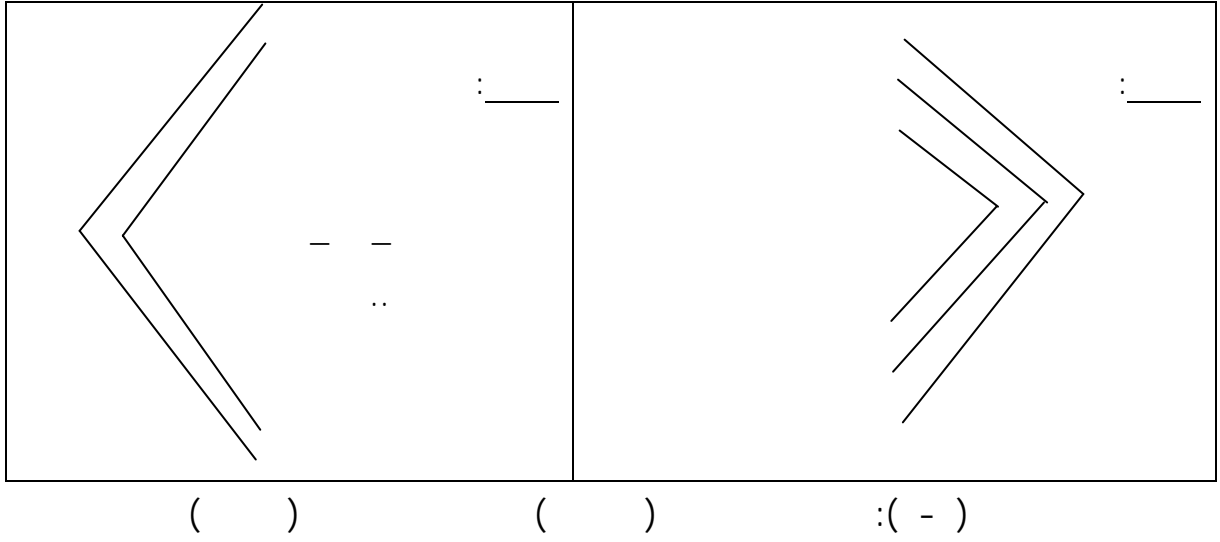

()

()

.()

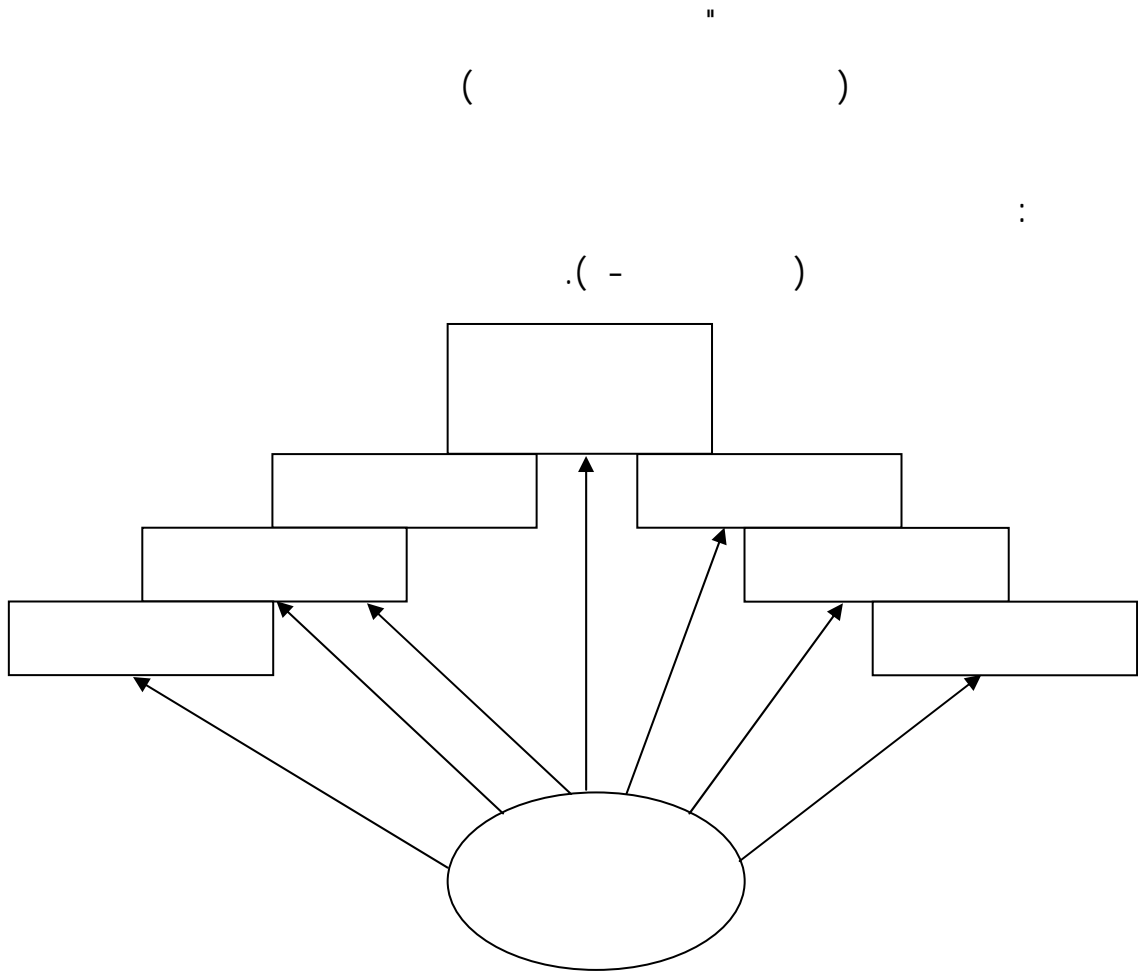

: ()
:

:

Jenkins
(Abdel Hamid , 2005)

)

(

)

.(

)

Roth Noller
Van Gundy

" (VanGundy,1987)

Isakssen

."

(Isakssen,et al.1994)

(

)

(

)

" "

:
.() -
.() -
-

.(Isakssen,et al.1994,VanGundy,1987)

()

-
- (1) Well structure
 - (2) Ill structure
 - (3) Critical Problem Solving
 - (4) Creative Problem Solving
-

.
:
() -
-
.
-
()
-
)

()
()
)

(
(Hayduk,1990)

-
.
()
:
"
":
)
:
()
:
()
:
()

·
" "

:
:

()

()

:
:

()

()

-

- ()
)

() (.... ()

.(-)

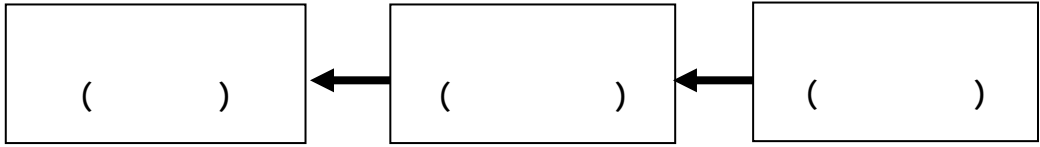

:(-)



(-)
)
.(

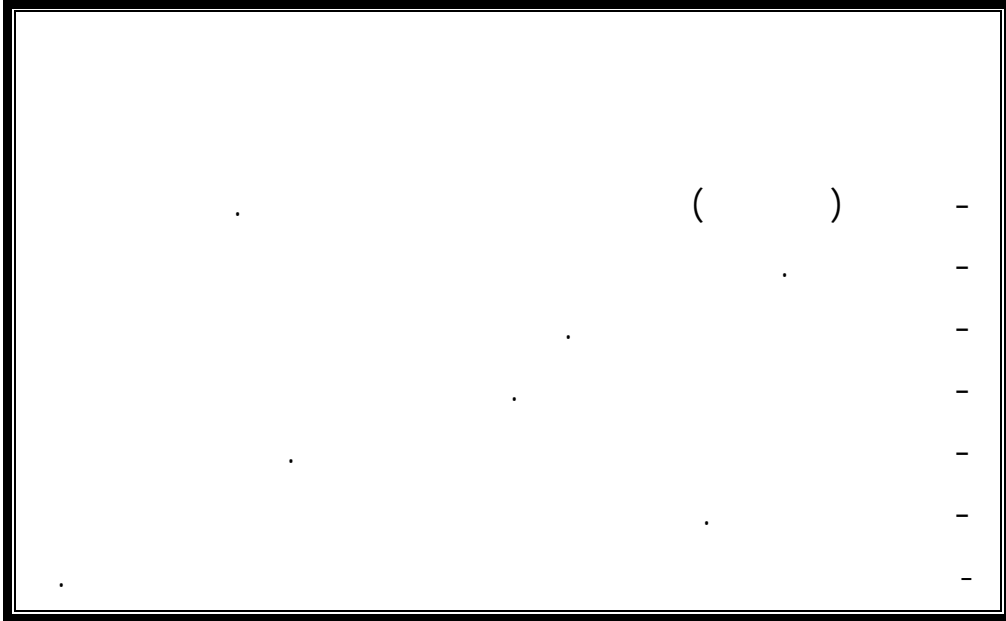

:(-)

()

(-)
(Osborn, 1953)

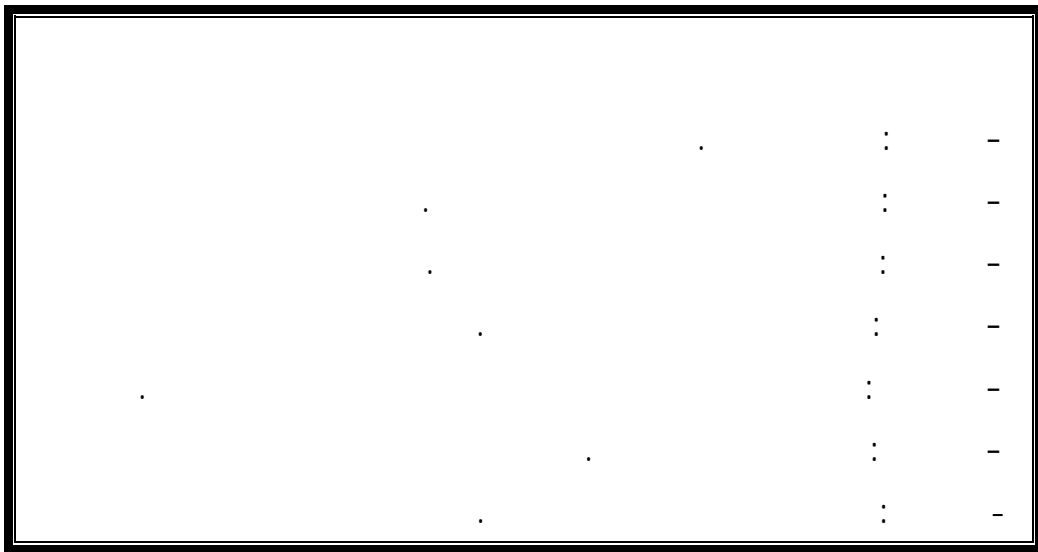

:(-)

(-) " " " "

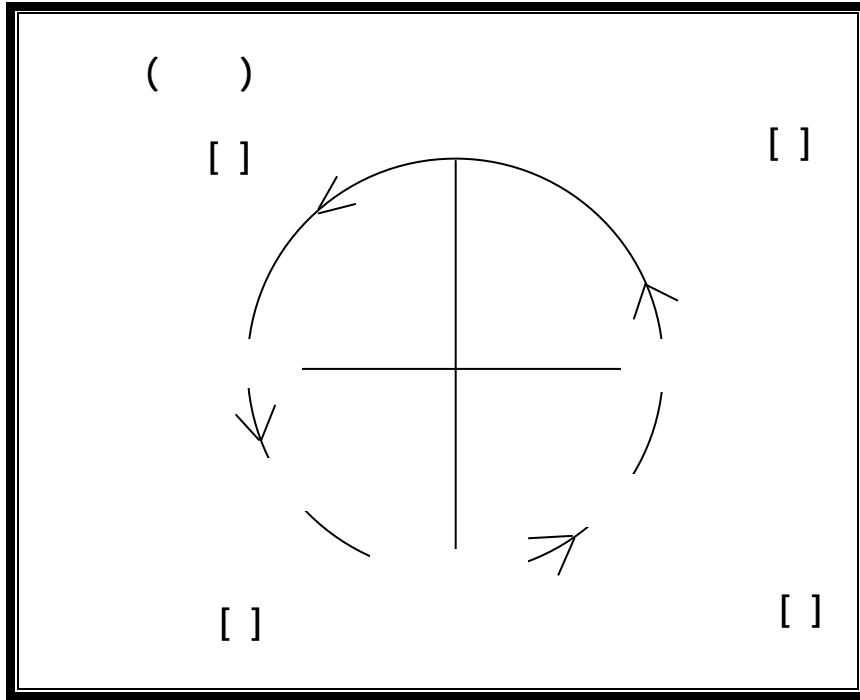

()

:(-)

()

see: Isaksen, Dorval, Trefernger, 1994))

()

-)

:

(

()

:

:() -

.
: -
.

:() -

:() -

:() -

:() -

:	:	•	<input type="text"/>
:	:	•	
:	:	•	<input type="text"/>
:	:	•	
:	:	•	<input type="text"/>
:	:	•	
:	:	•	<input type="text"/>
:	:	•	
:	:	•	<input type="text"/>
:	:	•	

:(-)

(:)

-

: " "

()

.

((-))

)

.

()

(....)

()

.()

[]

.

.

:

.

:

-

[]

.[]

:

-

[]

[]

.



[] : [] -
] : -
] [-
] .[-
] : [] -
.[] .[] -
] : [] -
.[] [] -
(-)

()

.()

-

)

(

)

.(

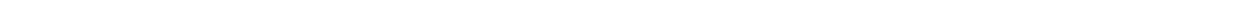

()

.()

.

.

-

:

()

.

()

· ()

()

.

()

.

()

: "

(-)] ()

"Bartlett

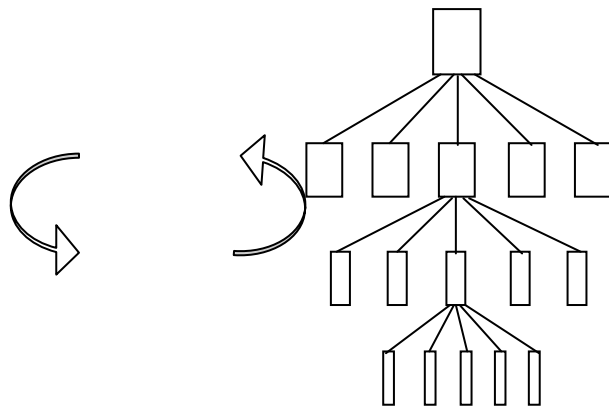

:(-)

:

)

.(

:(-)

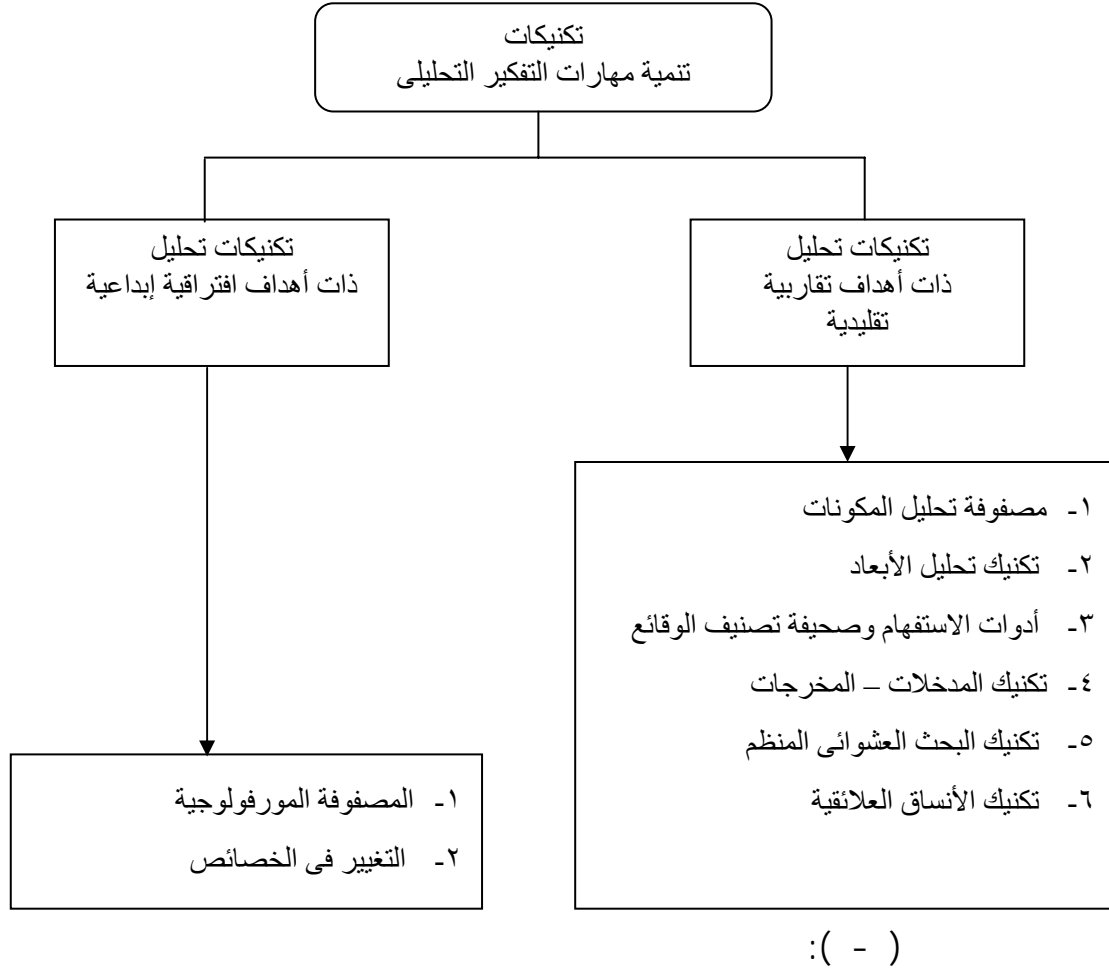

:(-)

} ()

[]

{

} ()

[]

{

_____:

-

-

(1) Decomposable matrices technique
 (2) Dimensional analysis technique

.(Van Gundy, 1988) :

:

:

- Herbert Simon

() : []

- (1) Input-Output technique
- (2) Organized random search technique
- (3) Relevance systems

.(-) .

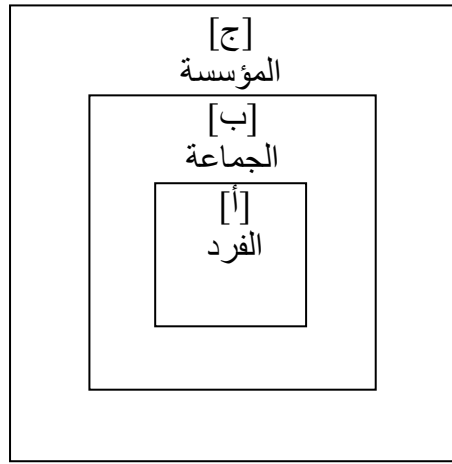

() :(-)

() () .
() (....)
() ()
() ()
" "

() (-)
() ()

:(-)

[-]	[-]	[-]	[-]	[-]	[-]	[-]	[-]	[-]	
									[-]
									[-]
									[-]
									[-]
									[-]
									[-]
									[-]
									[-]
									[-]
									[-]

Jensen

:

[]

:

() -

.

-

.

-

.

-

.

-

:

(-)

"

"

"

"

:

.

-

:

.

-

.(-)

.

-

.

-

:(-)

: []

.

(-)

:

.(-)

)

-

.(-)

(

.(-)

-

"

"

:

[]

.

:
.(IPm). (OP0) -
(LS) -
-

:(-)

)

(

)

:

(

-

-

[]

:

:

-

-

)

(

:

:

:

:

:

:

:

:

:

[]

()

()

()

()

()

()

()

()

()

()

()

()

()

()

()

() :

:(-)

Diagram showing a large rectangular frame containing a table and various symbols.

:	:	:
.....
.....	

Additional symbols and text within the frame include: - , . , : , () ,) , .(

:

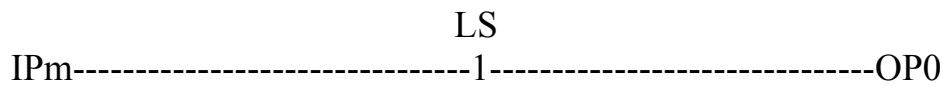

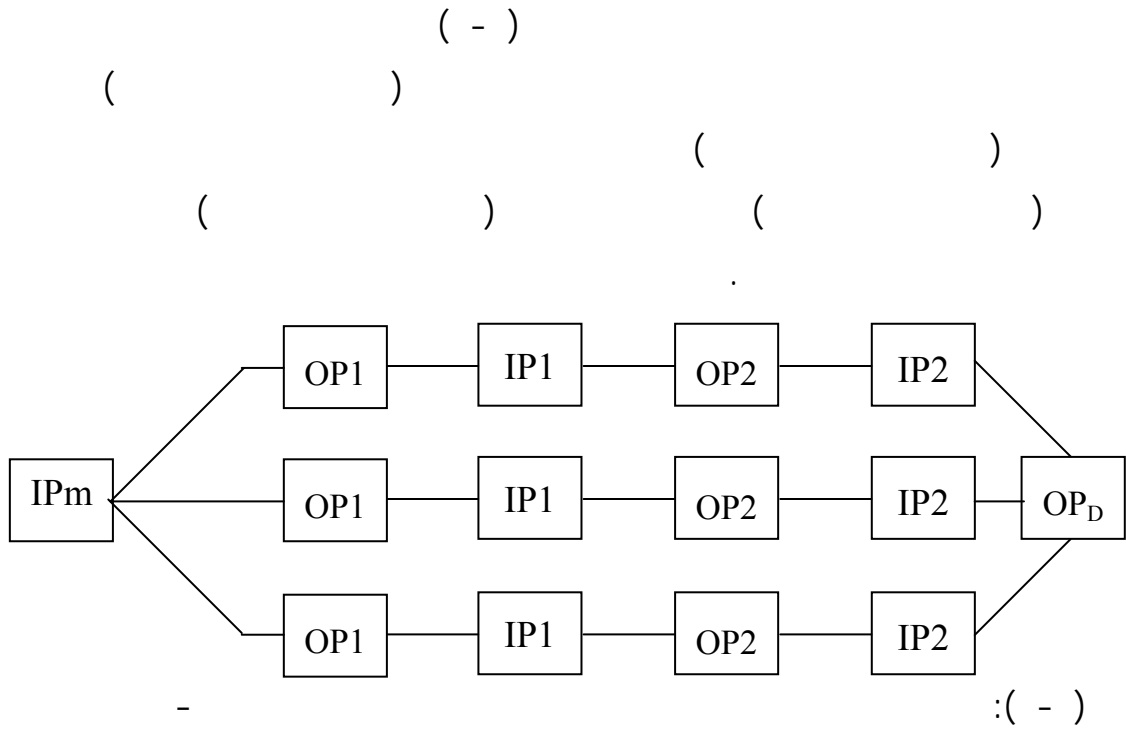

(Van Gundy, 1988,)

-
-
-
-
-
-

[]

Frank Williams

.

:

.

-

-

:

.

.

.

.

[]

(

)

.

.

" "

.

-

.

-

"

"

"

"

.

.

:

:

-

.

:

-

()

:

-

.()

-

)

.

-

)

:

:
(....

-

)

.(

-

-

-

_____ :
-

-

-

:

:

[]

")

.(Van Gundy, 1988,)

) (

"

:

[]

.(-)

-

() :

() ()

(Kirton, 1976, ()

.1989)

()

()

.

-

" "

:

(Isaksen ,et al.1994)

(Byrd,1986,Guastello,1998)

:

)

(

)

(

.

-

:

(

)

"

)

(

.

)"

(

)

:



(.....)

() ()
() ()
() ()

() ()
:

()
:

:()

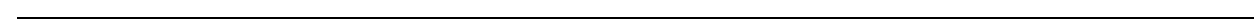

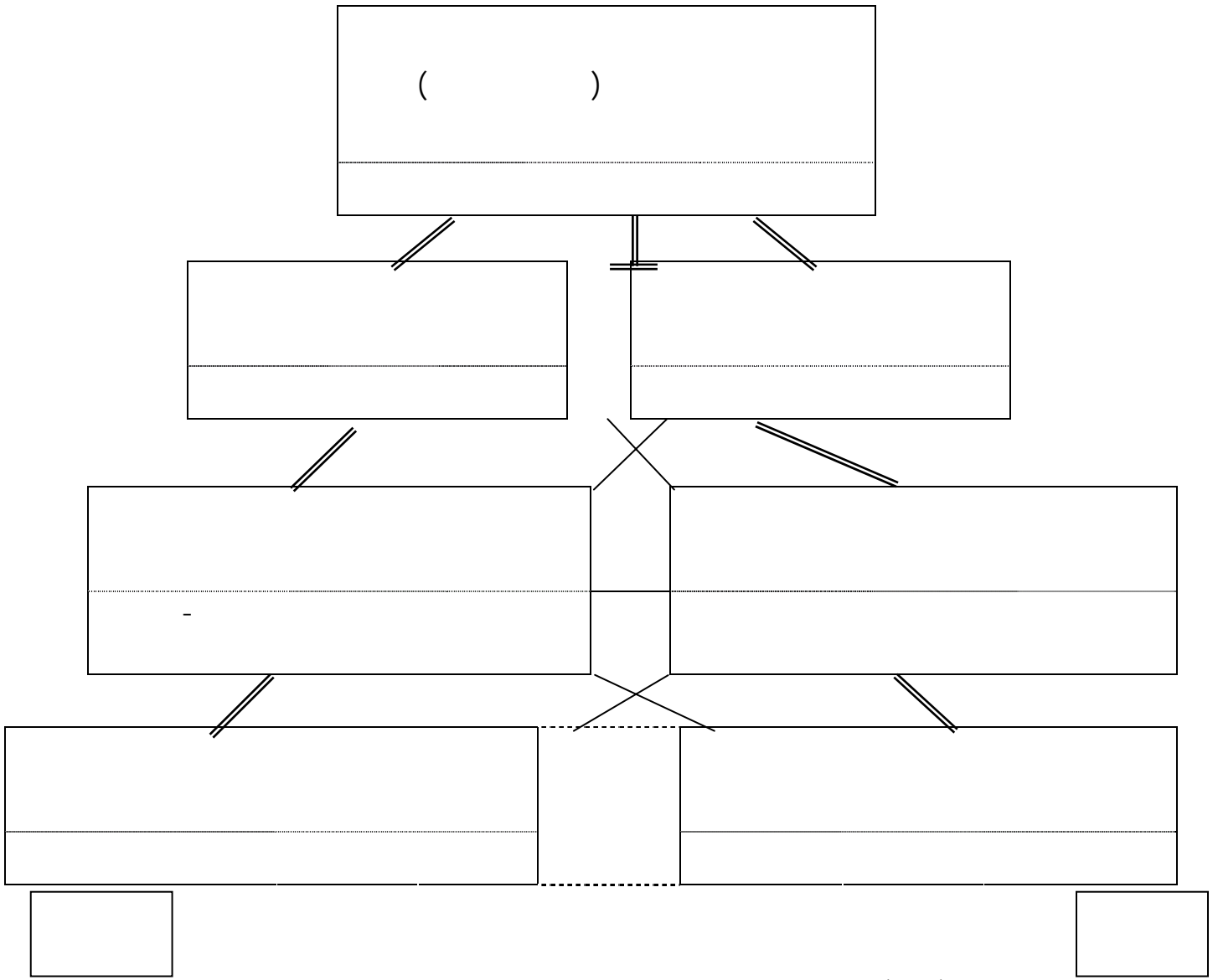

:(-)

(Wardell, Royce, 1978)

: -

()

.

.

.

:

-

.

.

:

-

.

∴

-

)

(....

.

:

-

.

.

-

" "

" "

:

" "

"

.

.

-

(.)

(Kirton, 1987)

-

:

.

.()

.()

" "

.

().

.() ()

-
- (1) analytic
 - (2) deductive
 - (3) rigorous
 - (4) constrained
 - (5) convergent
 - (6) formal
 - (7) critical
 - (8) synthetic
 - (9) inductive
 - (10) expansive
 - (11) unconstrained
 - (12) divergent
 - (13) informal
 - (14) creative
-

)

(

()

()

.

*

:

"

"

)

)

(

-

(*)

(" ")

(" ") " "

meta

(" " : " ")

Metacognition

(" ")

(conscious

(Passolungh et al.1996 Leaw, 2001) (Cheng, 1999, Neto&Volente, 2001)

(Verdschrift, et al., 1998, Vauras, 1999, Onghai, 2000)

(Feldhusen, 1995, Feldhusen &Goh 1996)

(Bonicatti,1983,

(Pizetacznik,1986, Ricciardelli,1992)

Carpenter,1991)

)

(McGlynn,1993, Macdonald, 1993)

(Scobee,1983, Miholic, 1991, Winsler, 1993)

(Magadi,1993, Istvan, 2001)

.(Flavell,1979) " "

(Lawson, 1984)

)

(Osborn, 1999a)

(Hacker,1998)

(Jausovec,1994)

()

()

()

.()

)

(

:
-
-
-
-
-
-
-
-
-

.()

(Pesut, 1990)

" ()

"Pesut

(Sternberg,1997)

.(Pesut,1990)

(Feldhusen,1995, Feldhusen & Goh 1996)

()

)

.(

(Patrick, 1992, P. 20)

:

."

"

[]

[]

)

()

)

(

(

)

(

:

-

-

-

-

-

-

:

:

"

(Flavell, 1979,)

" :

"

" "

"*

"

:

Kluwe

:

-

)

-

" "

)

(*) executive function

" " .

.(J.Osborn,1999a)

:

()

()

" " () "
" "

.()

" " (Lawson ,1984) "

.

"
" " " "

:

-

() :

.()

-

.

-

.

-

(....)

.

.

-

(Miles, 1999)

-

.

.

(Whitebread, 2000, Masui, De-corte, 1999)

(Masui, De-corte, 1999)

(Alexander, Schwanenflugel, 1996)

:

) () []
(

(Chen, Liu,1996)

(Clement, 1996(a), (b)

.(Treffinger, 1995, Miles, 1999)

() []

:

) ()
(

(Coletta,et al.1995, Betsinger et al.1994,Kramarski, 1997, Istvan,2001, Kim, 2000)((Jausovec,1994a, Jausovec, 1994b, Jausovec & Bakracevic, 1995, Hang,1999)

() ()

(Cheng, 1999, Neto &Volente, 2001)

(Leaw, (Passolungh et al.1996, Mevarech ,1999, Despete,et al., 2001)

2001)

(Vauras, 1999)

(Verdschrift, et al., 1998, Onghai, 2000,Vio et al., 1999)

) ()

(

.(Vauras, Kinnunen, Rauhanummi, 1999, Kitchner et al. , 2000)

:

()

-

.(Miles, 1999)

(De Grave, Boshuizen, Schmidt , 1996)

:)

: (

(Jausovec,1994 (a), Jausovec,1994 (b), Jausovec & Bakracevic)

(Coletta, et al.1995, Istvan, 2001)

:

:

:

-:

: []

(Patrick, 1992,P. 2)

(Data Show

.*(

: []

:

:

-

:

.

"

"

.

.

-

)

.

.

-

.

-

(

)

.

(*)

-

:

()

:

)

:

(

(:)

(,)

(,)

()

)

:

.

)

-

:

:

-

(-)

)

(

) (

.

:(-)

	=		=		
** , -	'	'	'	'	
** , -	'	'	'	'	
** , -	'	'	'	'	
** , -	'	'	'	'	
** ,	'	'	'	'	

(-)

:

.(/)

(-)

:(-)

	=		=			=		=		/
.	
.	
.	
.	
.	
.	
.	

(-) : -
()
()

:(-)

	=		=			=		=		
** , -	,	,	,	,	,	-	,	,		
.	-	,	,	,	,	-	,	,		
.		,	,	,	,	-	,	,		
,		,	,	,	,	-	,	,		
.		,	,	,	,	-	,	,		

(-)

:

-

:(-)

	=		=			=		=		/
**	'	'	'	'	'	'	'	'	'	
.	'	'	'	'	'	'	'	'	'	
.	'	'	'	'	'	'	'	'	'	
'	'	'	'	'	'	'	'	'	'	
.	'	'	'	'	'	'	'	'	'	

: :

-

(-)

)

)

(

-

(-)

:

-

.(/)

:(-)

	=		=			=		=		
**	'	'	'	'	'	'	'	'	'	
.	'	'	'	'	.	'	'	'	'	
.	'	'	'	'	'	'	'	'	'	
.	'	'	'	'	.	-	'	'	'	
.	-	'	'	'	'	'	'	'	'	

(-) : -

. :

(-) : -
()

(-) : -

.

-

:

-

()

-

:

-

"

.

-

-

:

" " " "

.()

·(Pesut, 1990)

" " " "

()

.

" "

.

" "

(Patrick,1992,p 20)

.

)

(

" "

.

"

"

" "

()

() ()

·
" "

)

(

(Kawenski, 1991, Fontenot,1987) (Brilhart, Jochem,1964, Huftel :)
(,1992)

)

(....

·

·

. : .() .() -
 : .() .() .() -
 : .() .() -
 :
() : .() -
 : :
 : .() .() -
 :
 : .() . -
 : .() .() -
 : ()
 : .() .() -
 : .()
 : .() .() -
 :
 : .() .() -
 : ()
 : .() .() -
 :
 : .() -
 :
() : : .() .
 : :

-
- Abd El Hamid. (2005). **Systems and creative thinking**, Pathways to Higher Education Project. Center for Advancement of Postgraduate Studies and Research in Engineering Sciences, Faculty of Engineering - Cairo University.
 - Amer (Ayman), (2005), **Analytical thinking**, Pathways to Higher Education Project. Center for Advancement of Postgraduate Studies and Research in Engineering Sciences, Faculty of Engineering - Cairo University (CAPSCU).
 - Bartlett G.,(2001). Systematic thinking, **The interactional conference of thinking**. Betsinger, A., Cross, J., DeFiore, (1994), **Problem solving and metacognition Perceptual-and-Motor-Skills**, Vol. 78, (3,pt 2) pp 1072- 1074.
 - Chen, Liu,(1996),**The strategy training of primary school pupils"formation of conjunctive concept and its transferring**, Acta psychological sinica, Vol. 28, (4). pp 367- 374.
 - Cheng, (1999), **Metacognition Training in physics problem solving**, **Psychological science china**, Vol. 22, No. 4. pp 365- 366.
 - Clement, D., (1986 a), Logo and cognition: **A theoretical foundation. computers in human behavior**,Vol. 2, (2). pp 95- 110.
 - Clement, D., (1986 b), Effect of logo and CAI environments on cognition and creativity. computers in human behavior,Vol. 2, (2). pp 95- 110.
 - Coletta,B. ,Buyer,L., Dominowsky,R., and Rellinger,E.(1995), Metacognition and problem solving: a process-oriented approach, **Journal of experimental psychology** , learning, memory,and cognition , Vol. 21, No. 1. pp 205- 223.
 - Desimone, R., Werner, J, Harris, D.(2002). **Human Resource Development. Fort Worth Texas**: Harcourt College Publishers, P.655, glossary.
 - Despete, Anmemie; Royers, Herbert; Buysse,-Ann.(2001). Metacognition and metamathematical problem solving in Grade 3.**J. of learning Disabilities**. Sep-Oct; Vol 34 (5): 435-449.
 - Feldhusen, j., (1995), Creativity:A knowledge base Metacognition skills ,and personality factors, **Journal of Creative Behavior**, Vol 29, No. 4. pp 255- 268.
 - Feldhusen ,J., & Goh,B., (1995), **Assessing and accessing creativity: An integrative review of their research**, and development. Creative research Journal, v 8(3) 231-247.
 - Flavell, J.H. (1979). Metacognition and cognitive monitoring: A new area of cognitivedevelopmental enquiry. **American Psychologist**, 34, 906-911. Guilford,1955.
 - Hacker, D., J., (1999), **Metacognition: Definition and empirical foundation**, (Internet: under review).
 - Hang,(1999) , **The relationship between well-structured and ill-structured problem solving in multimedia simulation**. Diss., section (A), Vol. 59(8-A): 2850.
 - Hayduk, Leslie A. (1991). Should model modifications be oriented toward improving data fit or encouraging creative and analytical thinking?. **Multivariate Behavioral Research**. Vol 25 (2) Apr 1990, 193-196.
 - Isaksen, S. G; Dorval, R. B.; and Treffinger, D.J. (1994). Creative approaches to problem solving. N.Y. Buffalo, Bearly limited.
 - Reber, A, (1985). Dictionary of Psychology. The penguin book.
-

-
- Istvan,Z., (2001), Afeladatmegoldast segito metakognitiv strategiak.//Problem solving:The fostering effect of meta-cognitive strategies. **Pszichologia: Az-MTA Pszichologiai intezetenek folyoirata**. 2001, vol 21 (1): 37-61.
 - Jausovec, N., & Bakracevic, k., (1995), What can heart rate tell us about the creative process? *Creative research Journal*, vol 8(1) 11-24.
 - Jausovec, N., (1994 b) ,Can giftedness be taught?, Report review,Vol 16(3) 210-214.
 - Jausovec, N.,(1994 a), Metacognition in creative problem solving , in: Runco (ed) ,Problem finding , **problem solving and creativity**. pp 77-95.
 - Jausovec, N.,(1994 a), Metacognition in creative problem solving , in: Runco (ed) ,Problem finding , **problem solving and creativity**. pp 77-95.
 - Kirton, M.J. (1976) Adaptors and innovators: A description and measures. **Journal of applied psychology**, 622-629.
 - Kirton, (1987), Adaptors and innovators: cognitive style and personality. in: Isaksen, S., G., (ED.), *Frontiers of creativity research*,N Y. Buffalo ,Bearly limited.
 - Kramarski, B., Mevarech,Z.(1997), *British Journal of Educational Psychology* , Dec Vol 67(4) 425-445.
 - Lawson, M. J., (1984), Being excutive about metacognition, (in): J. R. Kirby, *Cognitive strategies and educational performance*. Orlando: Academic press, inc.
 - Leaw, (2001), attention, awaareness, and foreign language behavior, *language learning*, 2001, vol 51 (suppl 1): 113-155.
 - Masui, -Chris; De-Corte.(1999). Enhancing learning and problem solving skills: Orienting and self - judging, two powerful and trainable learning tools. *learning and instruction*.Dec;Vol 9 (6): 517- 542.
 - Mevarech,- Zemira -R.(1999). Effects of metacognitive training embedded in cooperative settings on mathematical problem solving. *J. of Educational Research*. Mar -Apr; Vol 92(4): 195-205.
 - Neto, A., & Valente, M., (2001), Disonancias pedagogicas en la resolucion de fisica: Una propuesta para su superacion de raiz Vygotskiana. / pedagogical dissonances in physics problem solving: A proposal for overcoming based on Vygotskian. *Ensenaza de las ciencias*. vol 19 (1): 21-30.
 - Onghai, (2000), The use of metacognition to increase the attention, problem solving skills, and learning performance of school age children with attention deficit disorder. *Diss., section (A)*, Vol. 60(12-A): 4320.
 - Osborn, Jason W. (1999a) ,Assessing Metacognition in the classroom: The assessment of cognition monitoring effectiveness, *Time@"* MMMM d. yyyy16 october 1999" (Internet: under review).
 - Passolunghi, M., Lonciari,I., Cornoldi,C. ,(1996), Planning, comprehension , metacognition abilities and arithmetical word problems. *Eta evolutiva*. June no., 54 36-48.
 - Patrick, J.,(1992), *Training research and practice* , london , Academic press.
 - Pesut, D, J.,(1990), Creative Thinking as a self- regulatory metacognition process- A model for education,training and further research , *Journal of Creative Behavior*, Vol.24 , pp 105-110.
 - Pizetacznik, Gierowska, Maria.(1986). The role of language in the creativity of preschool children.*pszichologia Wychowawcza*; Vol 29(1) 2-19.
 - Soleman (Shaker abd-el hamed) (2005), *Systems and Creative Thinking, Pathways to Higher Education Project*. Center for Advancement of Postgraduate Studies and Research in Engineering Sciences, Faculty of Engineering, Cairo university (CAPSCU).
 - Standfast logic Ltd, (2001), *Analytical thinking*, ELECTRONIC DICTIONARY.
 - Sternberg R.,(1997), *Thinking styles*, New York: Cambridge university press.
-

-
- Sternberg, Robert.J. & OhsHara Linda A. (1999). Creativity and Intelligence. in R.J. Sternberg (Ed.). Handbook of creativity (pp 297- 311).
 - Treffinger, (1995), creativity problem solving: overview and educational implications. special issue: Toward an educational psychology of creativity. Educational psychology review, vol 7 (3): 301-312.
 - Van Gundy A., (1987). Creative problem solving; a guide for trainers and management, New York. Quorum Book.
 - Vauras, M., Kinnunen, R., and Rauhanummi, T., (1999), The role of metacognition in the context of strategy intervention. European Journal of educational psychology of education, vol 14 (4): 489-507.
 - Verdschrift, L., De Corte, E., Lasure, S., Van Vaerenbergh, G., Bogaerts, H., and Ratincks, E., (1998), Tijdschrift voor onderwijsresearch. vol 23 (3): 242-261.
 - Whitebread, David. (1999). Interactions between children's metacognitive abilities, working memory capacity , strategies and performance during problem solving. European-journal-of- psychology - of education. Dec; Vol 14: 489-507.
-